

WASA YACHTS AB  
VARVSVÄGEN 1  
151 39 SÖDERTÄLJE  
SWEDEN

# WASA ATLANTIC CRAFTSMANSHIP AND PERFORMANCE

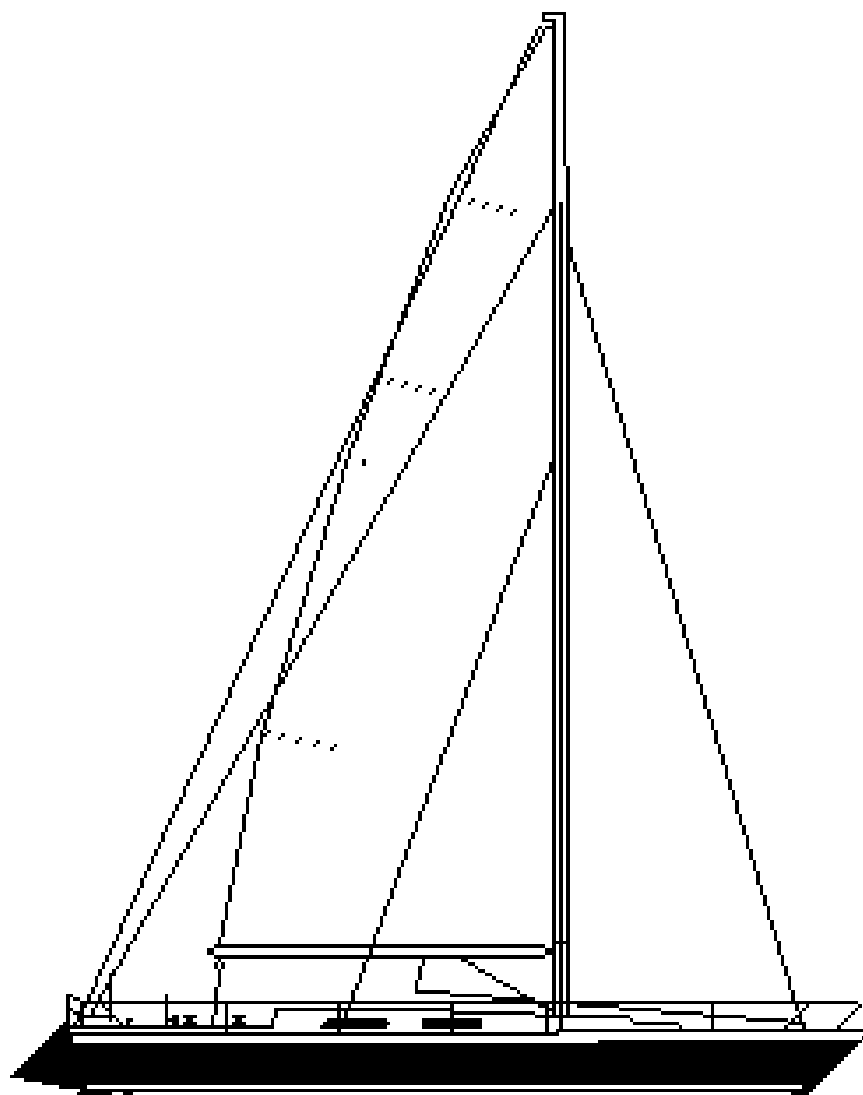

# WASA ATLANTIC

## CRAFTSMANSHIP AND PERFORMANCE

Wasa Atlantic is the ultimate combination for both racing and cruising. The boat is well adapted for IMS but also for the IRM rule. It is a fast cruising yacht. The interior is done with the best boat builder's craftsmanship. Selected teak or mahogany is used for wooden work.

In the shipyard, just outside Stockholm, where Wasa Yachts is situated; pleasure boats have been built since the beginning of this century. Wasa Yachts was established in 1976 and has over the years built more than 400 yachts, all of the over 36 feet.

Leif Ängermark designs our boats. A Swedish designer well known for designing fast sailing yachts. Every single detail of our boats is specified to meet the requirements of safety, maneuver capability, speed and convenient living. Equipment such as engines, winches mast etc is delivered by manufactures well known for quality and customer service. The interior is of teak or mahogany chosen from the best pieces of lumber and built with traditional Swedish craftsmanship. We have done our outmost to give you the best comfort and pleasure of your sailing.



---

### THE WASA ATLANTIC CONCEPT

---

The concept behind Wasa Atlantic and all Wasa Yachts is modern design, light, strong and stiff sandwich hulls combined with effective riggings and sails. The idea is to create a yacht easy to sail, even with a small crew. That's why we have put a lot consideration to the manoeuvrability of the yacht. The balanced ruder together with the short but solid keel and a large mainsail will create a yacht easy to manoeuvre under sail in narrow waters and harbours. This will also crate a boat well balanced under all

conditions something Wasa sailors appreciate and frequently miss when sailing other boats. The modern and light hulls together with a generous sail area produces the well-known Wasa speed.

---

**BUILT FOR SAILORS BY SAILORS**

---

With Wasa Atlantic we have created a fast and comfortable family racer with a modern design., a winner for the selective offshore racer as well as a fast and safe family cruiser. Wasa Atlantic is constructed and built for the sailor with high ambitions for quality and comfort., we at Wasa have made no compromises when designing and building the yacht..

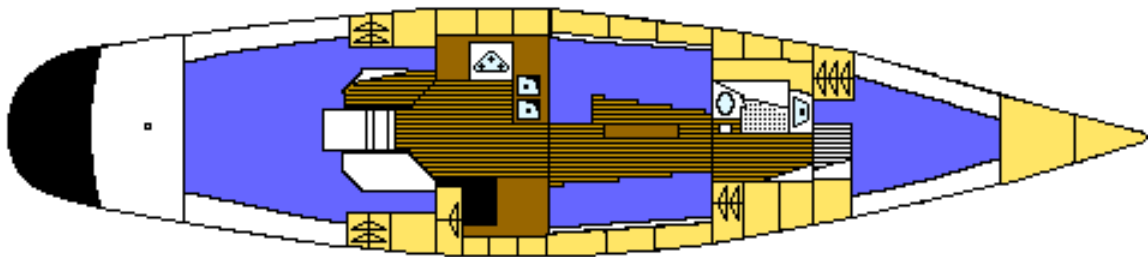

---

**COMFORT BOTH AT SEA AND IN THE HARBOR**

---

To live comfortably both at sea and in the harbor is A and Z if all onboard will enjoy the voyage. In the Wasa Atlantic the interior layout is built on experience from many years of offshore racing and cruising with the family.

**BASIC DATA**

L.O.A.	15,45 M
L.W.L.	12,00 M
BEAM	3,30 M
DRAFT	2,15 M
DISPL.	6 500 KG
BALLAST	KG
I	14.50 M
J	4,64 M
P	16.40 M
E	5,95 M
IMS RATING	

## TECHNICAL SPECIFICATION

### CONSTRUCTION

#### HULL

WASA YACHTS has designed a special moulding technique, unique in boat construction, which allows us to mold the hull in one piece.

To achieve a first rate product, WASA YACHTS is using a special selected polyester with supreme test result regarding:

- Stretch/break factor
- Pliability ratio factor
- Water saturation factor
- Adhesive factor
- Strength factor
- Material fatigue
- Polyester density

All these factors are very important in combination with the environmentally controlled moulding area. During the molding process it is very important to keep temperature and humidity at a predetermined controlled level.

The hull is made in GRP sandwich construction, using end grain balsa core and fibre-glass mats of different specifications.

All stress areas are specially strengthened with unidirectional rowing reinforcement in the direction of the stress. All through hull fittings are in solid GRP. Structural bulkheads are of marine grade waterproof plywood, laminated to hull and deck.

Transverse floor beams and longitudinal stringers are built up of GRP, unidirectional rowing using a high density core. There are limber holes in the floors to allow drainage. Specially designed KEVLAR combination mat, in hull and deck (option)

#### DECK

The deck is made in GRP balsa core sandwich construction. All high stress areas are specially reinforced with selected material using the same technique as in the hull.

The deck has a high strength / weight ratio and is through-bolted with stainless steel (AISI 316) to the hull. The mountings for the deck fittings and have been extra reinforced.

#### BALLAST

A new keel shape has been developed based on extensive tank testing and practical test on ONE-OFF WASA Racing yachts.

The keel shape has the following advantages in comparison with an conventional keel:

- Higher lift - drag ratio.
- Lower centre gravity, increasing stability without adding ballast weight.
- Shorter cord length at top and tip, improving laminar flow and lower drag.

- The increased stability gives better performance and seaworthiness.

The fin keel, casted to high accuracy in lead with added antimony. The keel is through bolted to the hull with 6 cast in stainless steel keel bolts, (1 1/4" x approx 2' AISI 329).

#### RUDDER

The cantilevered balanced spade rudder is made of GRP filled with high density foam. The 60 mm solid stainless steel shaft (Special ordered Swedish stainless steel with three times tensile strength of AISI 316) passes through a low friction, non water absorbent bearing, mounted and strongly bonded to the hull.

The rudder was originally developed for our racing yachts, design the Swedish Royal Technical Institute. It has an impact zone, with external forces above 2 tons, the lower part of the rudder will give away, still possible to navigate the yacht.

#### ENGINE BED

Originally designed by VOLVO PENTA is incorporated into the hull. Special care is taken to ensure a rigid foundation and correct bonding.

#### CHAIN PLATES

Stainless steel through-bolted to longitudinal bulkheads which are securely bonded to hull and deck. The plates, large in areas, provided with backing plates.

#### STEAM HEAD FITTINGS

Custom stainless steel fabricated fitting provided with jib tack

#### TOE RAIL

Anodized aluminium toe rail with one pair of hawsaw holes, amidships drain holes where necessary.

#### HARDWARE AND FASTENINGS

Best quality marine standard used throughout. Several of them designed and produced by WASA YACHTS.

#### INTERIOR

All joiner-work is done in accordance with the best yacht practice using first grade materials. Selected teak is used for all visible wood-work. Floor boards with laid teak veneer, providing access to the bilge, topsides lined with teak ribs. Overhead lined with vinyl panelling. All doors provided with retaining hooks and swing stops. Kick plates on steps and chafing pieces on sills are provided.

Hanging lockers are equipped with rods and hooks and their doors are provided with ventilation louvres.

## EQUIPMENT

### COMPASS

Silva 6" card compass mounted in dome pinnacle of steering pedestal with appropriate lighting.

### SAFETY EQUIPMENT

A pulpit and pushpit of best quality stainless steel (AISI 316) are through-bolted to the bow and transom. Double life lines are installed, passing through stainless steel (AISI 316) stanchions. The life lines are stainless steel wire and plastic coated. The pulpit is fitted with navigation lights and the pushpit with a stern light. The height of the pulpit, stanchions spacing distance etc, conform to Off-shore Racing Committee requirements.

### HATCHES AND VENTILATION

- Forehatch - hinged type with tinted glass. LEWMAR
- Midship hatch - hinged type with tinted glass. LEWMAR
- Main companionway hatch - sliding-tinted LEXAN with lock and wash-boards.
- Aft cabin - two opening ports with screw-down fasteners mounted i cockpit well. LEWMAR

### WINDOWS

The windows in cabin trunk are made of tempered glass with anodized aluminium frames, bolted through the cabin trunk. They meet class 3 specification for off-shore racing yachts.

### VENTILATION

3 Elektrolux stainless steel ventilators. 2 Dorade ventilators.

### HAND RAILS

Ample hand and grab rails provided in teak.

## **MACHINERY**

### ENGINE

Engine: VOLVO PENTA 2030  
No of cylinders: 3 in line  
Power output: 30 Hp  
Electrical: 12 volts, insulated return  
Alternator: 12 V 55 amps  
Gearbox: S-drive or shaft  
Propeller: 2 blade folding or 3 blade bronze folding propeller (option)  
Flexible engine mountings. "Wet" exhausted with special rubber tubing and muffler.  
Fuel consumption approximately 4 liters / hour, depending on weather and throttle

### FUEL SYSTEM

Fuel capacity approx 120 litres (32 US gallons) in one stainless steel (AISI 316) tank with shut-off valve. Water separator on fuel feed line. The tank is vented to aft coamings, and are single deck mounted fill, marked FUEL. All fuel lines and shut-off are to standards. Extra fuel tanks as option.

### PROPELLER SHAFT

The propeller shaft is made of 30mm diameter, stainless steel ((AISI 316) fitted with flexible shaft coupling. Outboard end supported with bearing. Stuffing-box with hose connection to stern tube. Zinc anode on shaft.

## **ELECTRICAL**

### BATTERY AND WIRING

12 V/DC two-wire system for lights, instruments and battery charger Two battery switches, for engine and electrical installations, are mounted in the aft cabin.  
4 x 75 amp hours marine deep cycle batteries, secured in GRP boxes Selected high grade insulated copper wire, with different diameter, prevent minimum voltage drops.  
The system is numeric coded for easy check and maintenance.

### CONTROL PANEL

The control panel is designed and manufactured by WASA YACHTS. To help achieve a trouble free electrical system, the panel is a printed circuit board, with LED indicators showing operating status.

A two bank volt meter together with a water / fuel gauge are incorporated in the panel. All functions on the panel are hand engraved on a non corrosive aluminium plate. The panel is hinged for easy inspection.

### SERVICE LIGHTING

Inside the control panel compartment, under the pantry (water pumps, and refrigerator compressor), in the motor room (maintenance oil check) and in the aft locker, (steering mechanism aft equipment).

## EXTERIOR LIGHTING

Pair side lights (red/green). Stern light (high intensity white). Deck flood light (white). Mast-head light (white). Compass light (red).

## INTERIOR LIGHTING

Navigator's light. 8 spot lights. 6 roof top lights. 4 Night lights (red).(option)

## CHARGING SYSTEM

55 amp 12 v alternator on the engine. Starting and service batteries charge simultaneously with separation provided by current blocking diodes.

## PLUMBING

### SEACOCKS

Seacocks of forged bronze chrome plated for all below water-line through-hull fitting. Sea-water and fresh water piping of reinforced PVC marine quality.

### DRAINAGE SYSTEM

The cockpit is self draining and the installation is made in accordance with Off-shore Racing Committee's category 3 specifications.

The galley sink drains through a separate seacock. There are two manual bilge pumps - one at the mast foot one in the cockpit with outlets above water-line. In addition to the two manual bilge pumps, there is an electric pump in the bilge. Both showers are equipped with electric pumps.

### FRESH WATER SYSTEM

1 stainless steel (AISI 316) tank with a capacity of 120 litres with deck filling, marked WATER. Separate shut-off. The tank vent pipe drains into the galley sink. Extra water tank are option.

### SEA WATER SYSTEM

Electrical pump for galley sinks.

### TOILETS

1 Par toilets with sea water pump, shut off and drainage pump. Septic tank in stainless steel (AISI 316)

### STOVE

Gimbaled gas stove with oven. Drained gas-bottle stowage in cockpit, vented outboard. Shut-off valve at stove and gas-bottle.

## **SPARS**

### **MAIN MAST**

Manufactured by SELDÉN/WASA YACHTS. Silver anodized aluminium alloy hollow with oval section. The mast is wired internally for head light, bow and deck flood light. The mast has aluminium aerofoil section spreaders, halyards are internal. Appropriate exit sheaves and swivel exits for topping lifts and spinnaker halyard blocks are provided. Spinnaker pole track and heel hoist.

### **MAIN BOOM**

Silver anodized aluminium alloy hollow section. Slab reefs with cheek blocks.

### **SPINNAKER POLES**

Anodized aluminium alloy with fitted sheave on outboard end and stud fitting on inboard end, as option.

## **STANDARD RIGGING LIST**

### **GENERAL**

Rigging is in stainless steel (AISI 2343) wire with appropriate fittings and toggles. 1/19 stainless steel (AISI 2343) wire

1 headstay                      1 backstay  
2 upper shrouds              2 lower shrouds  
2 intermediate shrouds

### **RUNNING RIGGING**

7/19 stainless steel (AISI 2343) wire plus terylene tails as standard.

- Main halyard with stainless steel shackle 12 mm
- Genua halyard 12mm
- Main sheet 14 mm
- Main clew outhaul 12 mm
- Reefing line 12 mm
- Flattening reef 12 mm
- Cunningham line 12 mm
- Boom vang with shackle 12 mm
- Genoa sheet 14 mm
- Spinnaker halyard with snap shackle LEWMAR 12 mm (option)

- Spinnaker sheets with snap shackle LEWMAR 12 mm (option)
- Spinnakerpole lift with snap shackle LEWMAR 10 mm (option)

#### WINCH LIST

- 2 LEWMAR 54 self tailing
- 4 LEWMAR 44 self tailing

#### WINCH HANDLES

2 x Lock in 10"

#### STANDARD EQUIPMENT

- Anchor line 85 m - 16 mm (250 feet x 5/8")
- 6 fenders (air-filled)
- 1 flagpole
- 4 LEWMAR genoa sliders
- 1 15 kgs anchor
- Manuals for engine, plumbing and electrical system